

Twist Drill Grinder

Operation Manual

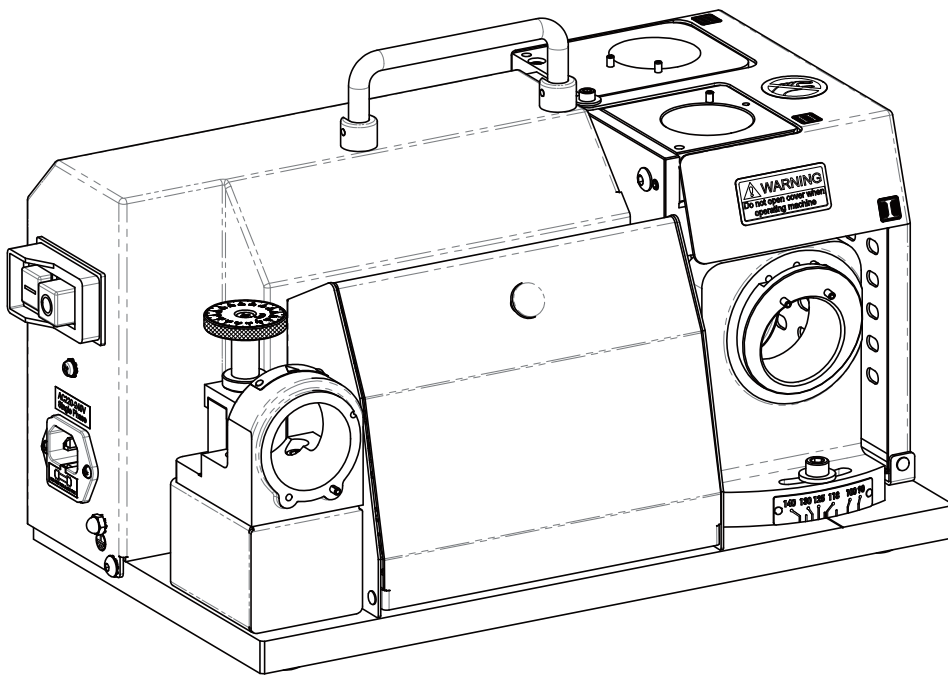

Model : GS-34

RECYCLING



Do not dispose of electrical appliances as unsorted municipal waste, use separate collection facilities.

Contact your local government for information regarding the collection systems available.

If electrical appliances are disposed of in landfills or dumps, hazardous substances can leak into the groundwater and get into the food chain, damaging your health and well-being.

When replacing old appliances with new ones, the retailer is legally obligated to take back your old appliance for disposal at least for free of charge.

Ground, cord-connected tools intended for use on a supply circuit having a nominal rating less than 150 volts:

Warning:

When using electric tools basic safety precautions should always be followed to reduce the risk of fire, electric shock and personal injury including the following.

Read all these instructions before attempting to operate this product and save these instructions.

1. Keep work area clear
 - Cluttered areas and benches invite injuries.
2. Consider work area environment
 - Do not expose tools to rain.
 - Do not use tools in damp or wet locations.
 - Keep work area well lit.
 - Do not use tools in the presence of flammable liquids or gases.
3. Guard against electric shock
 - Avoid body contact with earthed or grounded surfaces (e.g. pipes; radiators, ranges, refrigerators)
4. Keep other persons away
 - Do not let persons, especially children, not involved in the work touch the tool or the extension cord and keep them away from the work area.
5. Store idle tools
 - When not in use, tools should be stored in a dry locked-up place, out of reach of children.
6. Do not force the tool
 - It will do the job better and safer at the rate for which it was intended.
7. Use the right tool
 - Do not force small tools to do the job of a heavy duty tool.
 - Do not use tools for purposes not intended; for example do not use circular saws to cut tree limbs or logs.
8. Dress properly
 - Do not wear loose clothing or jewellery, they can be caught in moving parts.
 - Non-skid footwear is recommended when working outdoors.
 - Wear protective hair covering to contain long hair.

9. Use protective equipment
 - Use safety glasses.
 - Use face or dust mask if working operations create dust.
10. Connect dust extraction equipment
 - If the tool is provided for the connection of dust extraction and collecting equipment, ensure these are connected and properly used.
11. Do not abuse the cord
 - Never yank the cord to disconnect it from the socket. Keep the cord away from heat, oil sharp edges.
12. Secure work
 - Where possible use clamps or a vice to hold the work. It is safer than using your hand.
13. Do not overreach
 - Keep proper footing and balance at all times.
14. Maintain Tools with care.
 - Keep cutting tools sharp and clean for better and safer performance.
 - Follow instruction for lubricating and changing accessories.
 - Inspect tools cords periodically and if damaged have them repaired by and authorized service facility.
 - Inspect extension cords periodically and replace if damaged.
 - Keep handles dry, clean and free from oil and grease.
15. Disconnect tools
 - When not in use, before servicing and when changing accessories such as blades, bits and cutters, disconnect tools from the power supply.
16. Remove adjusting keys and wrenches
 - Form the habit of checking to see that keys and adjusting wrenches are removed from the tool before turning it on.
17. Avoid unintentional starting
 - Ensure switch is in "off" position when plugging in.
18. Use outdoor extension leads
 - When the tool is used outdoors, use only extension cords intended for outdoor use and so marked.

19. Stay alert

- Watch what you are doing, use common sense and do not operate the tool when you are tired.

20. Check damaged parts

- Before further use of tool, it should be carefully checked to determine that it will operate properly and perform its intended function.
- Check for alignment of moving parts, binding of moving parts, breakage of parts, mounting and any other conditions that may affect its operation.
- A guard or other part that is damaged should be properly repaired or replaced by an authorized service centre unless otherwise indicated in this instruction manual.
- Have defective switches replaced by an authorized service centre.
- Do not use the tools if the switch does not turn it on and off.

21. Warning

- The use of any accessory or attachment other than one recommended in this instruction manual may present a risk of personal injury.

22. Have your tool repaired by a qualified person.

- This electric tool complies with the relevant safety rules. Repairs should only be carried out by qualified persons using original spare parts, otherwise this may result in considerable danger to the user.

23. Please use the air spray gun to move away the metal just which remains inside the grinding wheel protection over after finishing the grinding job.

24. Please take a duster to clean the adjustment shelf and two grinding shelf after finishing grinding job.

A- weighted sound pressure level: $L_{p,eq} = 66.24 \text{ dB(A)}$
 $L_{p,eq} = 66.8 \text{ dB(A)}$

Warning:

1. KEEP GUARDS IN PLACE and in working order.
2. REMOVE ADJUSTING KEYS AND WRENCHES. Form habit of checking to see that keys and adjusting wrenches are removed from tool before turning it on.
3. KEEP WORK AREA CLEAN. Cluttered areas and benches invite accidents.
4. DON'T USE IN DANGEROUS ENVIRONMENT. Don't use power tools in damp or wet locations, or expose them to rain. Keep work area well lighted.
5. KEEP CHILDREN AWAY. All visitors should be kept safe distance from work area.
6. MAKE WORKSHOP KID PROOF with padlocks, master switches, or by removing starter keys.
7. DON'T FORCE TOOL. It will do the job better and safer at the rate for which it was designed.
8. USE RIGHT TOOL. Don't force tool or attachment to do a job for which it was not designed.
9. USE PROPER EXTENSION CORD. Make sure your extension cord is in good.
10. WEAR PROPER APPAREL. Do not wear loose clothing, gloves, neckties, rings, bracelets, or other jewelry which may get caught in moving parts, Nonslip footwear is recommended. Wear protective hair covering to contain long hair.
Exception: The reference to gloves may be omitted from the instructions for a grinder.
11. ALWAYS USE SAFETY GLASSES. Also use face or dust mask if cutting operation is dusty. Everyday eyeglasses only have impact resistant lenses, they are NOT safety glasses.
12. SECURE WORK. Use clamps or a vise to hold work when practical. It's safer than using your hand and it frees both hands to operate tool.
13. DON'T OVERREACH. Keep proper footing and balance at all times.
14. MAINTAIN TOOLS WITH CARE. Keep tools sharp and clean for best and safest performance. Follow Instructions for lubricating and changing accessories.
15. DISCONNECT TOOLS before servicing; when changing accessories, such as blades, bits, cutters, and the like.
16. REDUCE THE RISK OF UNINTENTIONAL STARTING. Make sure switch is in off position before plugging in.
17. USE RECOMMENDED ACCESSORIES. Consult the owner's manual for recommended accessories. The use of improper accessories may cause risk of injury to persons.

18. NEVER STAND ON TOOL. Serious injury could occur if the tool is tipped or if the cutting tool is unintentionally contacted.
19. CHECK DAMAGED PARTS. Before further use of the tool, a guard or other part that is damaged should be carefully checked to determine that it will operate properly and perform its intended function - check for alignment of moving parts, binding of moving parts, breakage of parts, mounting, and any other conditions that may affect its operation. A guard or other part that is damaged should be properly repaired or replaced.
20. DIRECTION OF FEED. Feed work into a blade or cutter against the direction of rotation of the blade or cutter only.
21. NEVER LEAVE TOOL RUNNING UNATTENDED. TURN POWER OFF. Don't leave tool until it comes to a complete stop.

IN DOOR USED!!!

WARNING: DO NOT EXPOSE TO RAIN OR USE IN DAMP LOCATIONS.

Index

I.	Machine Devices Introduction.....	7
II.	Machine Installation Instruction.....	8
III.	Type of Drill for Sharpening.....	8
IV.	Dust Collection Adapter Assembly Steps.....	9
V.	Choose of Grinding Wheel & Collet.....	10
VI.	Chuck Set Assembly Steps.....	10
VII.	The use of the Positioning Shelf.....	11
VIII.	Drill Grinding.....	13
IX.	The use of the Parallel Alignment Device.....	15
X.	The use of Metal Shims.....	15
XI.	Machine Maintenance and Clean.....	16
XII.	Trouble Shooting.....	17

I. Machine Devices Introduction

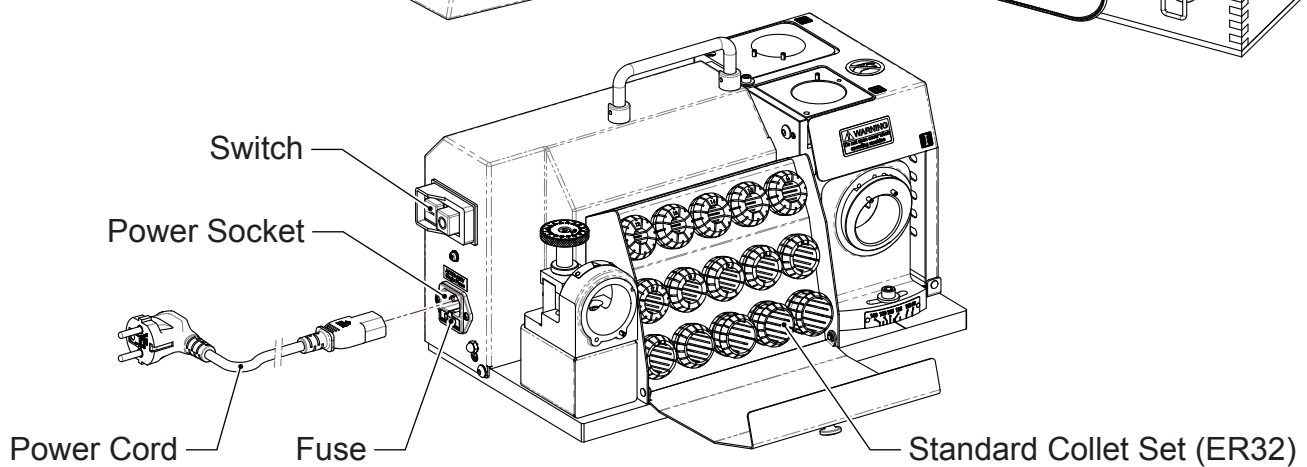
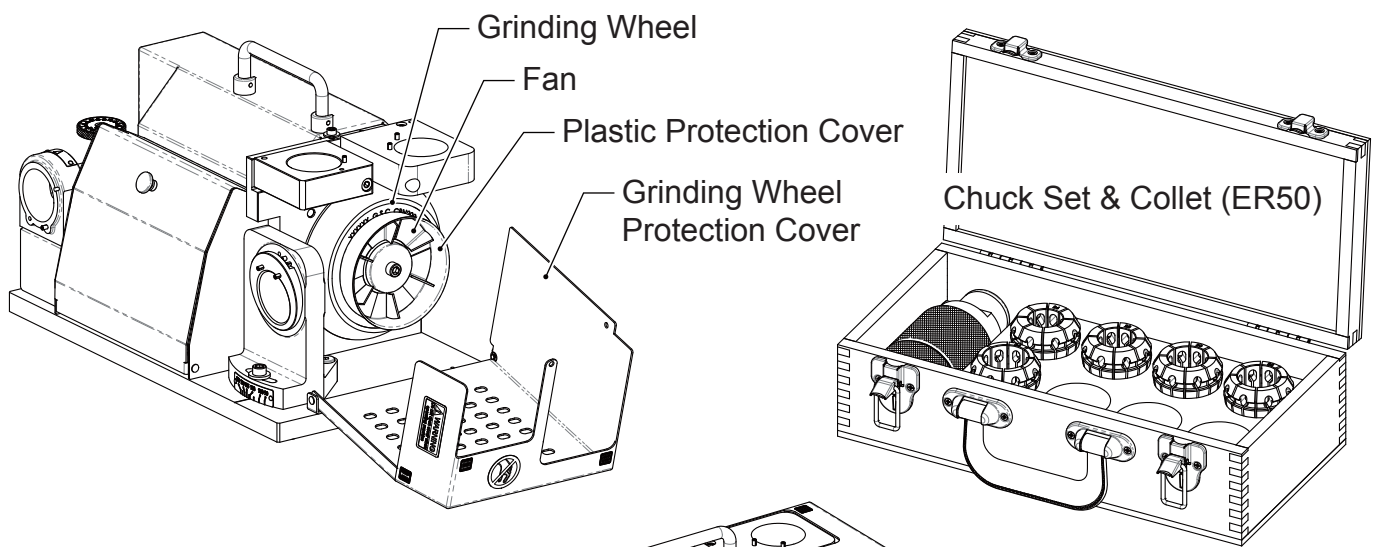
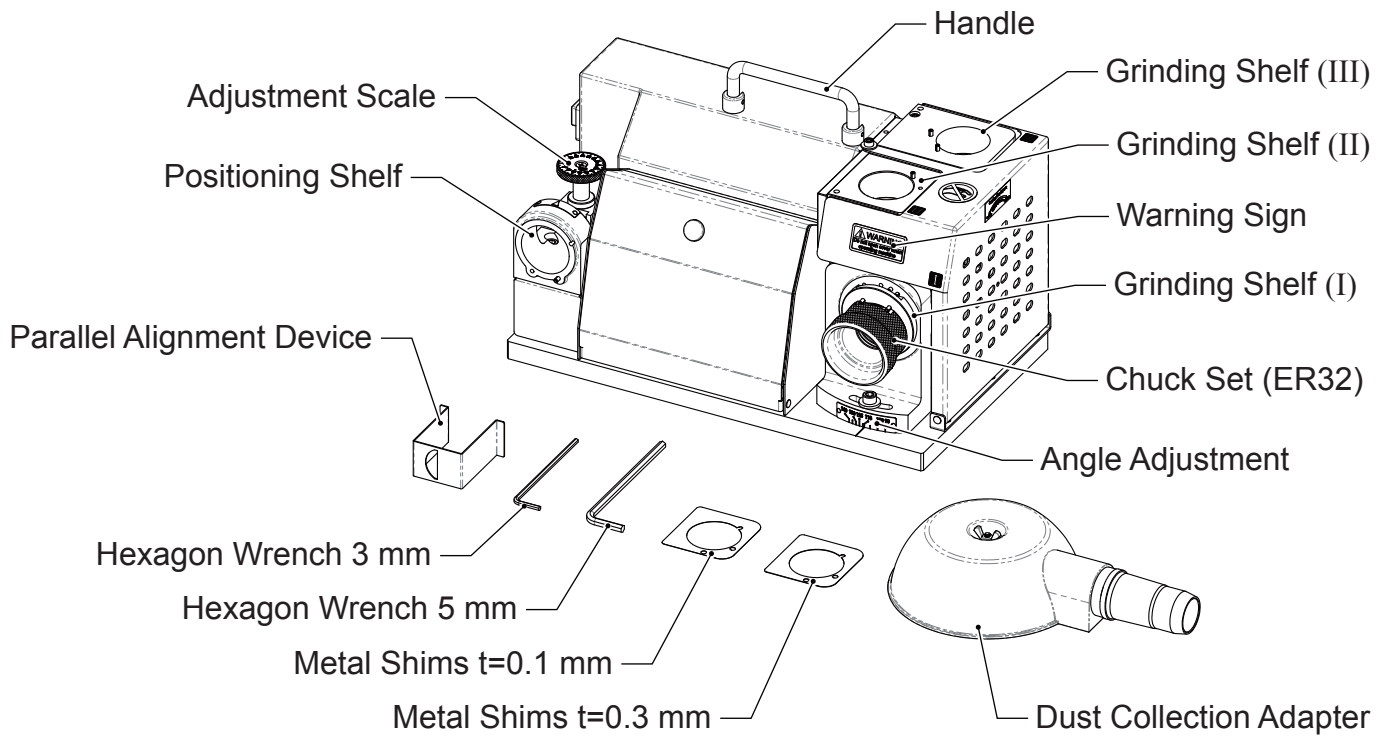

For drill diameter: $\Phi 12.0$ mm - $\Phi 34.0$ mm

II. Machine Installation Instruction

1. Environmental Condition

- Place the machine on a “flat” and “stable” working table.
- Operate the machine in dry environment and away from liquid.
- Make sure power plug and power cord are installed in proper location.

2. Power Supply

Make sure the local power supply is matching with the voltage specification from the product label.

Please check the switch is in off position before plugging into socket outlet.

3. Motor Direction Test

- ① Plug the power cord into socket outlet.
- ② Check the grinding wheel protection cover is fastened by the screw.
- ③ Quickly switch on and off the machine, then check if the rotating direction of grinding wheel is **counterclockwise**.
- ④ Switch on the machine again and check if any abnormal sound.

(The Machine is equipped with DC current carbon motor. A slightly grinding sound is considered as normal condition.)

III. Type of Drill for Sharpening

This machine is design for sharpening General HSS / Carbide Twist Drill.

Universal Twist Drills



CNC Spotting Drills 120°

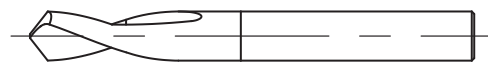

CNC Spotting Drills 90°

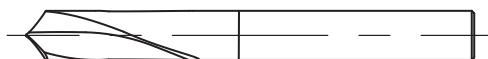

Taper Shank Twist Drills



Deep-Hole Drills and Coating



Noss Drills



IV. Dust Collection Adapter Assembly Steps

1. Thread the hex nut onto the proper position of the threaded rod, align the end of the threaded rod containing the hex nut with the tapped hole of grinding wheel cover, and turn the threaded rod clockwise to thread the rod into the grinding wheel cover and tighten lightly. (Fig. 4-1)

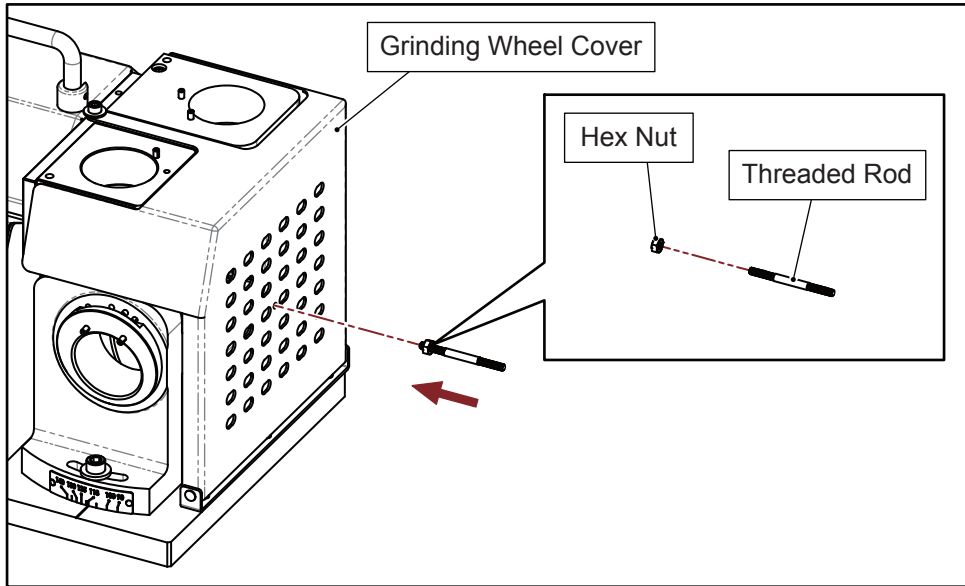

Fig. 4-1

2. Align the hole in the center of the dust collection adapter with threaded rod. Push the dust collection adapter to the end. (Fig. 4-2)
3. Assemble the washer and wing nut and tighten the wing nut to secure the dust collection adapter. (Fig. 4-3)

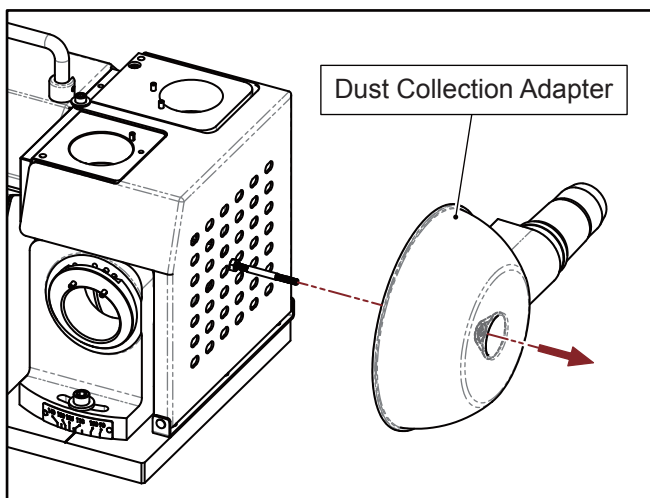

Fig. 4-2

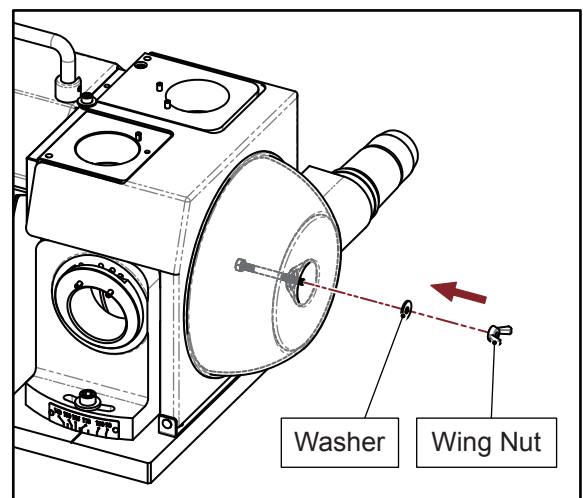

Fig. 4-3

V. Choose of Grinding Wheel & Collet

1. Please unplug the power cord before changing grinding wheel.
2. Determine the material of the Drill and choose the proper grinding wheel.
 - HSS material Drill use CBN grinding wheel (Standard).
 - Carbide / Tungsten material Drill use SD grinding wheel (Optional).
3. According to the drill diameter and choose the proper collet.
Eg: 12 mm drill, use 12 mm collet ; 13.5 mm drill, use 14 mm collet.

VI. Chuck Set Assembly Steps

1. Make sure there are no dusts or scraps inside the collet and the collet holder.
2. Put collet into collet holder by 45° angle. (Fig. 6-1)

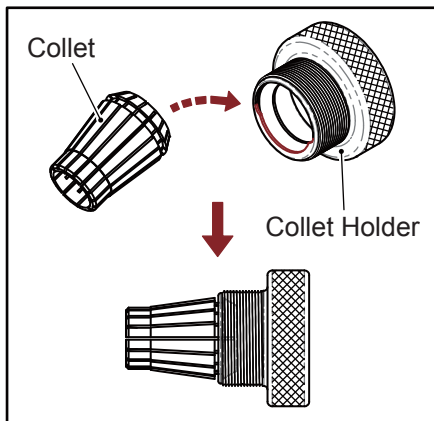

Fig. 6-1

3. Screw in a little bit by clamping nut (Fig. 6-2 Step ①), then insert the drill through the collet holder (Fig. 6-2 Step ②), and push in until the drill is out of the clamping nut about 15 mm. (Fig. 6-3)

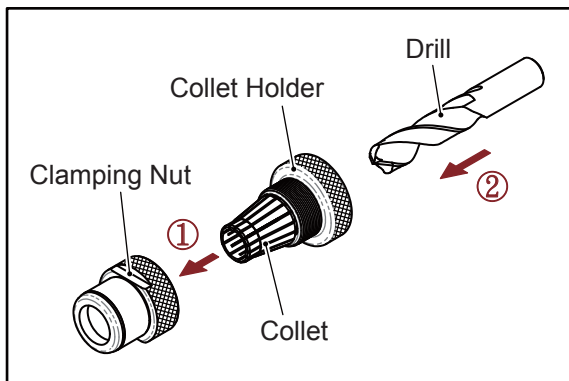

Fig. 6-2

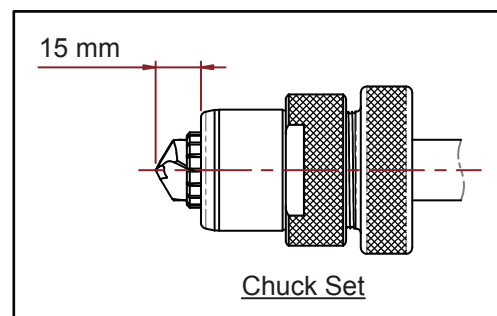

Fig. 6-3

✘ Please do not fully tighten the chuck set, keep the drill is still able to be adjusted.

VII. The use of the Positioning Shelf

1. Preset the scale of the Positioning Shelf. (Fig. 7-1)

- ① Turn it by clockwise to the end.
- ② Turn it by counterclockwise at "0".

2. Adjust the scale according to the drill diameter.

Eg: 12.1 - 13.0 mm drill, set at 13;

13.1 - 14.0 mm drill, set at 14.

- If the length of a drill is shorter than original length after re-sharpening many times, the scale should be increased until the cutting edge is parallel with slot of clamping nut.
- For grinding **High Spiral Drill Bit**, please increase the scale more than its diameter.
- For grinding **Deep Hole Drills**, the scale is adjusted to 2 times of the drill diameter.
Eg: Deep Hole Drill, diameter at 15 mm, the scale should adjust above 30.

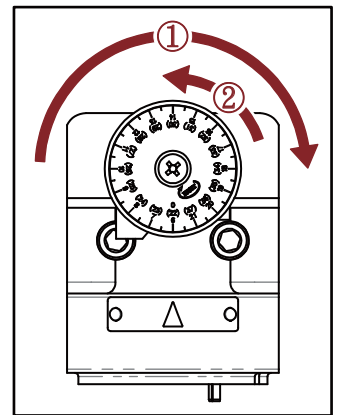

Fig. 7-1

3. Drill Positioning (Fig. 7-2)

- ① Insert the Chuck set into the Positioning Shelf, align slot of the clamping nut with the pin on the Positioning Shelf, then connect it closely without any interval and turn it clockwise to the end.
- ② Push the drill to the end and turn it by clockwise until it is blocked by the Position block.
- ③ Turn the collet holder clockwise and tighten lightly the Chuck set.
- ④ Rotate the Chuck set counterclockwise and take it out gently.

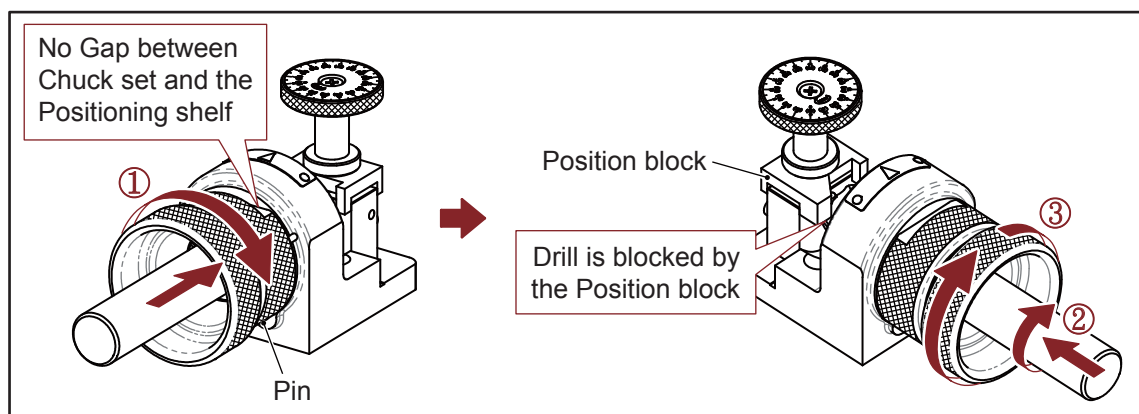

Fig. 7-2

- ※ After taking the Chuck set out, make sure the cutting edge of the drill is parallel with the slot of clamping nut (Fig. 7-3), if it is not parallel, please re-adjust it. (Fig. 7-4)

(continued on next page)

(continued from previous page)

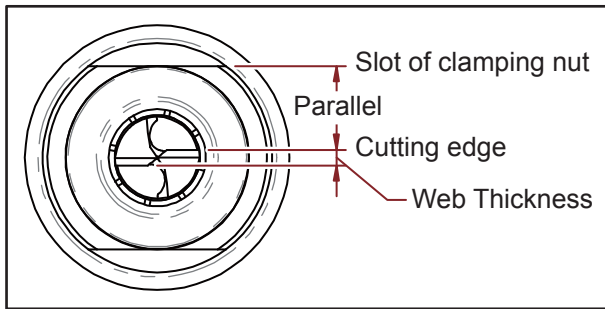

Fig. 7-3

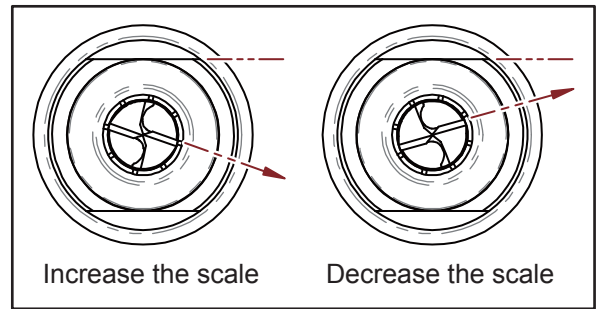

Fig. 7-4

- ✘ You could also choose to use the parallel alignment device to check the parallelism (See chapter “IX. The use of the Parallel Alignment Device”)
- ✘ Always keep the parallelism before starting the grinding procedure. (Fig. 7-3)

VIII. Drill Grinding

- ※ Please verify the point angle of the drill and adjust the angle of the Shelf (I) before starting the grinding procedure. (Point angle 90° - 140° is available for the Shelf (I) adjustment.)
- ※ Adjustable point angle as follows: 90° for NC spotting only.
 - 12.0mm ~ 26mm - 90° - 140°
 - 26.1mm ~ 32mm - 118° - 140°
 - 32.1mm ~ 34mm - 125° - 140°

Turn the power switch on and wait about 10 seconds until the motor rotation is stable.

1. Cutting Lip Grinding (Fig. 8-1)

- ① Insert the Chuck set into the Shelf (I), the slot of clamping nut must fit with the two pins of the shelf, push the Chuck set gently and turn it clockwise and counterclockwise until the grinding noise stops.
 - ② Take the Chuck set out, turn it to the other side and grind the drill in the same way.
- ※ While grinding, please do not hold the drill shank, it may influence the drill position and caused the missing of accuracy.

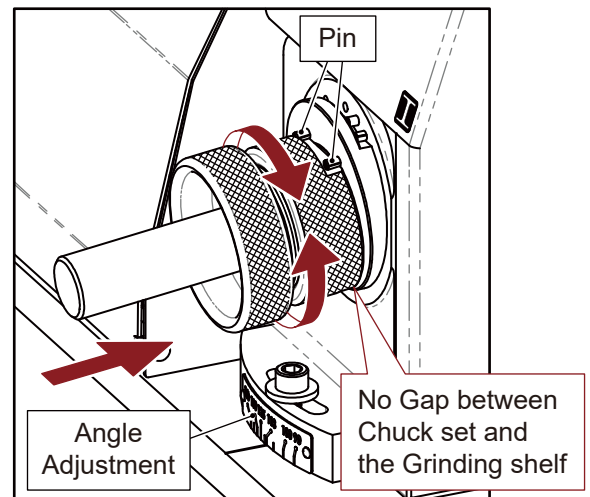

Fig. 8-1

2. Web Thinning Grinding (Fig. 8-2)

- ※ Align the center part of the clamping nut slot with the pin on the Shelf (II) when putting in or taking out the Chuck set.
- ① Insert the Chuck set into the Shelf (II), and grind the drill by turning clockwise and counterclockwise until the grinding noise stops.
 - ② Take the Chuck set out, turn it to the other side and grind the drill in the same way.

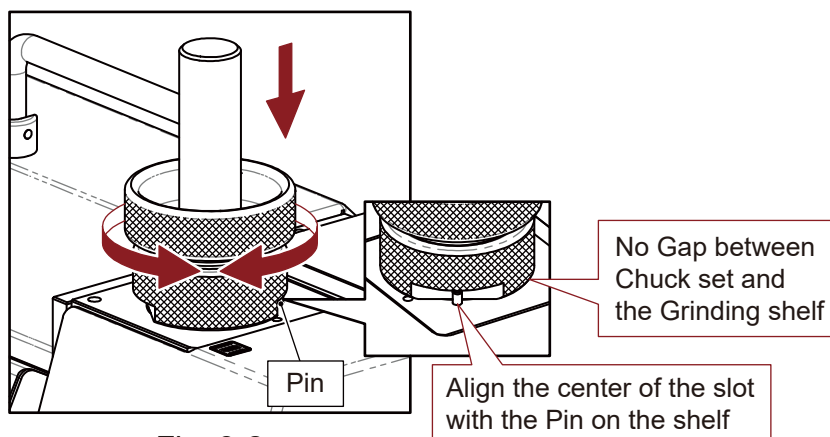

Fig. 8-2

- ※ There are 0.1mm shim and 0.3mm shim for adjusting the size of web thickness. (See chapter "X. The use of Metal Shims")

3. Heel Grinding (Fig. 8-3)

- ① Insert the Chuck set into the Shelf (III), the slot of clamping nut must fit with the two pins of the shelf, push the Chuck set gently until the grinding noise stops.
- ② Take the Chuck set out, turn it to the other side and grind the drill in the same way.

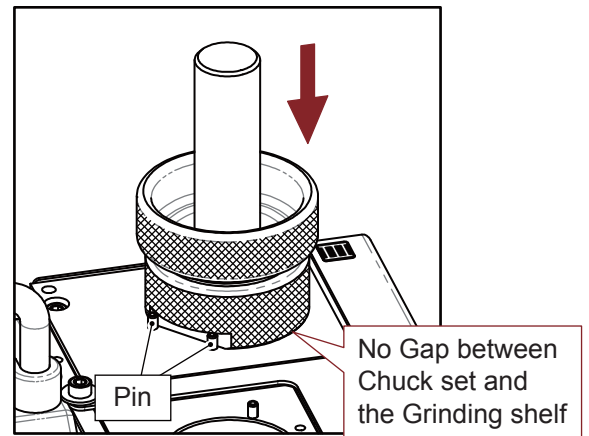
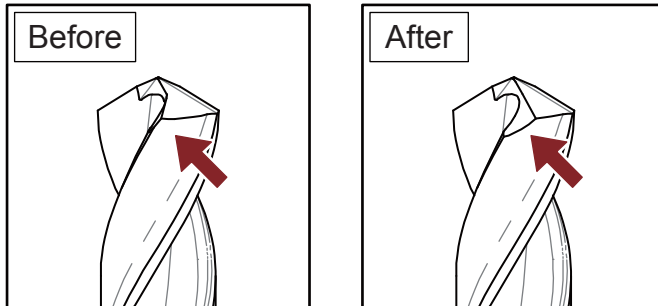
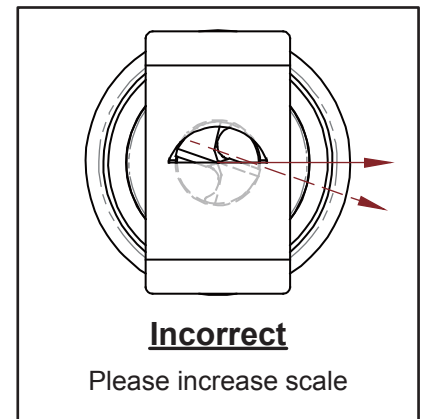
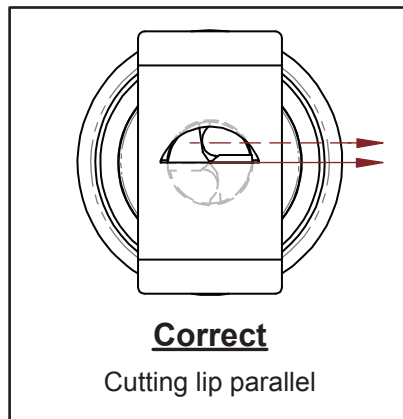
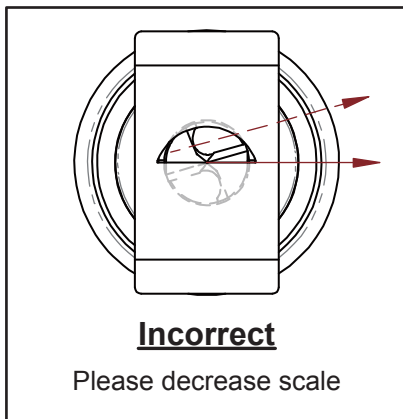
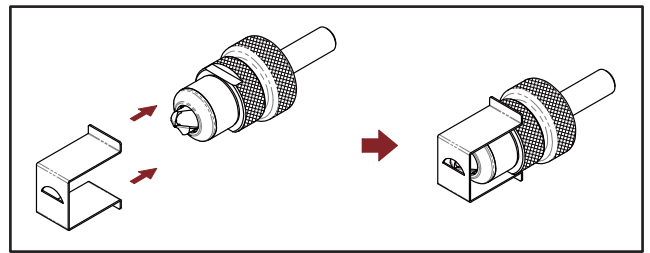

Fig. 8-3

IX. The use of the Parallel Alignment Device

Align the Parallel Device with the two slots of the clamping nut, then connect them as shown in the right picture.

Verify the parallelism of the Drill's Cutting Lip with the flat figure of the hole on the Parallel Device.



X. The use of Metal Shims

There are 3 pieces Metal Shims as standard accessories in the machine.

- 2 pieces of 0.1 mm Metal Shims.
- 1 piece of 0.3 mm Metal Shims.

Adding one shim of 0.1 mm will expand 0.2 mm of the point size, adding 0.3 mm shim will expand 0.6 mm of the point size and so on.

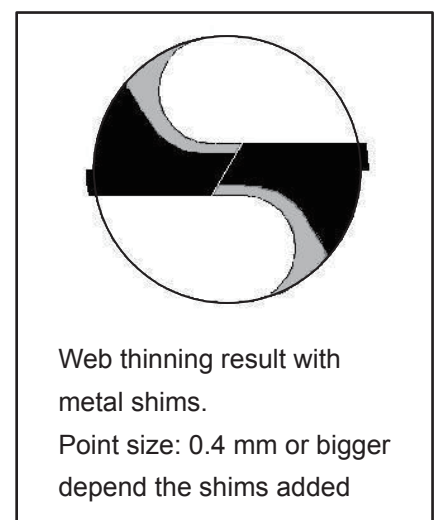
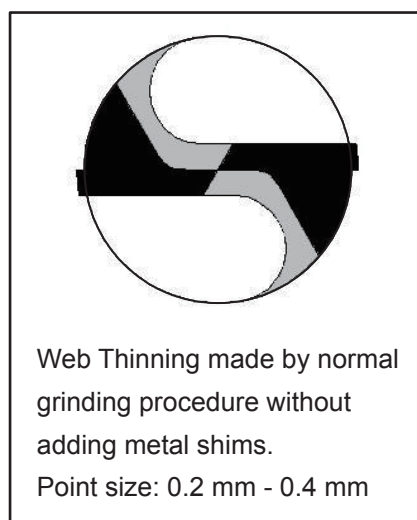
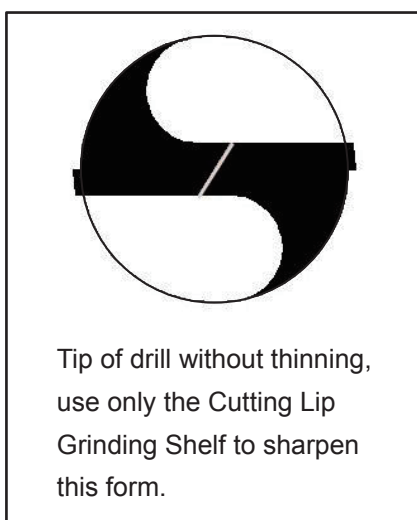
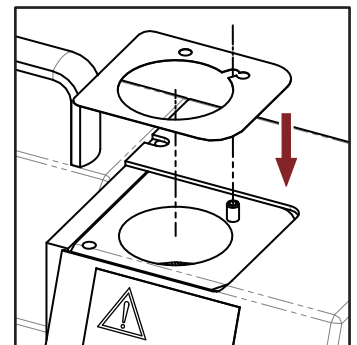

XI. Machine Maintenance and Clean

1. Replacement of Grinding Wheel

- ① Unplug the power cord and make sure the power is off.
- ② Confirm the screw direction on the grinding wheel cover before changing the grinding wheel. (Fig. 11-1)
- ③ Loosen the screw from the grinding wheel cover to open the cover. (Fig. 11-2)
- ④ Loosen the screw from the grinding wheel to take off the grinding wheel. (Fig. 11-3)
- ⑤ Use clean cloth to clean the flange and the contact surface of the grinding wheel.
- ⑥ Replace the new grinding wheel and fasten the screw. (Fig. 11-3)
 - ✘ *Tighten the wheel screw until the fan can't be moved separately, do not over tighten.*
 - ✘ *Do NOT exchange our grinding wheel with other grinding wheel from other supplier!*
- ⑦ Close the grinding wheel cover and secure with screw.

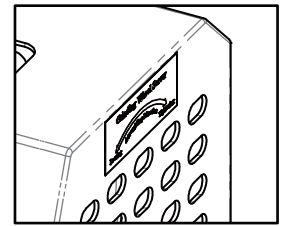

Fig. 11-1

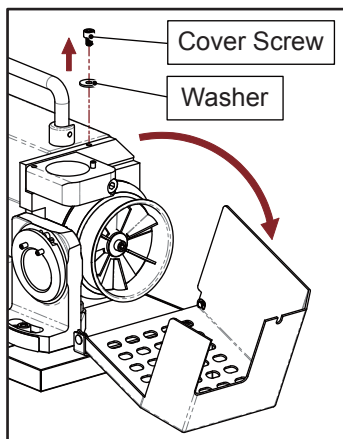

Fig. 11-2

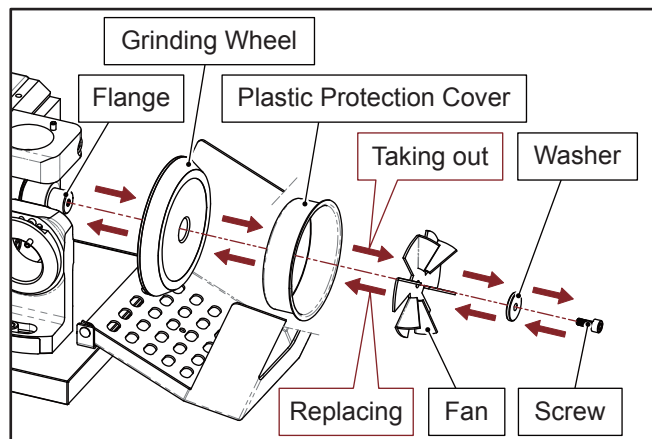

Fig. 11-3

2. Cleaning

- ① Unplug the power cord and make sure the power is off.
- ② Disassemble the chuck set after use.
- ③ Use the air press gun to clean the scraps and dust out of all grinding shelves and all the accessories. (Fig. 11-4) (Fig. 11-5)
 - ✘ *Please wear protection glass while using the air press gun.*
- ④ Use clean cloth to clean each contact port and all the accessories, then put them back in order. (Fig. 11-4) (Fig. 11-5)

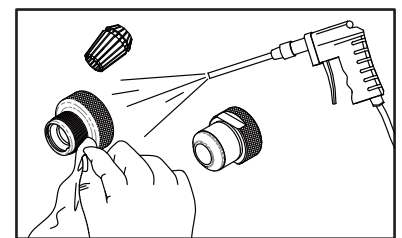

Fig. 11-4

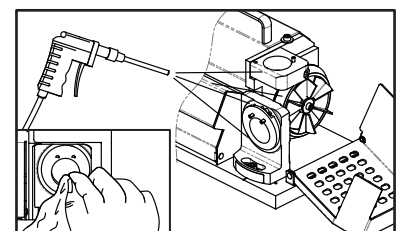

Fig. 11-5

XII. Trouble Shooting

1. Cutting edge / lip can not be parallel with the slot of clamping nut.
 - ① Check the cutting edge of the drill to see whether scraps / iron ash existed - clean the drill.
 - ② Check the scale of the Positioning Shelf. (See chapter “VII. The use of the Positioning Shelf”)
 - ✘ *Must turn the scale to the end by clockwise first and set the scale at “0”.*
 - ③ Check the diameter of a drill and adjust the scale according to drill diameter. (See chapter “VII. The use of the Positioning Shelf”)
 - ④ Check the position block on the Positioning shelf, if it is damaged, please contact with your agent for replacement.
 - ⑤ When adjusting the length position, make sure the chuck set is tightly connect to the shelf without gap. (See page 11, Fig 7-2)

2. Positioning Tolerance upward to 10° (Fig. 12-1)

Before starting the grinding procedure, please check the cutting edge is parallel with the slot of clamping nut.

The cutting edge can be upward from 0° - 10° but no more than 10° .

✘ *It is unacceptable, if the cutting edge is downward with the slot of chuck set.*

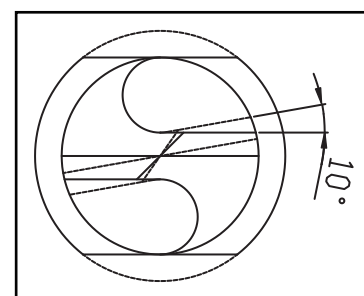
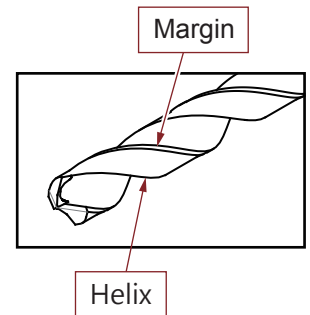

Fig. 12-1

3. Positioning is parallel but failed accuracy after grinding.
 - ① Check the condition of position block. Please contact with your agent for replacement.
 - ② While operating, check chuck set is tightly connect to any of the grinding shelf without gap. (See page 13, Fig 8-1 and Fig 8-2 ; page 14, Fig 8-3)
 - ③ Check the drill is fastened tightly by chuck set. (See page 11 “3. Drill Positioning”)
 - ④ Check the point angle of the drill complies with the point angle adjustment set.
Eg: 135° drill, the point angle adjustment set should be adjusted to 135°
- ✘ *Please re-adjust the web scale and re-grinding the drill again for point ②, ③, ④.*

4. Unequal Flank / Land of a drill after grinding

- ① Check the clearance of chuck set (collet / collet holder / clamping nuts).
- ② Check the drill, Helix of a drill has burr or damaged, the parts should be cut off.
- ③ Check the drill; it can not be used when the drill is deformed.
- ④ While grinding, do not apply too much pressure to the shelf.
- ⑤ Check the screw of point angle adjustment set is fastened enough.
- ⑥ Check the contact surface of grinding shelf and chuck set that is clean without scraps.
- ⑦ Check the margin of the drill, damaged margin should be cut off.
- ⑧ While grinding, make sure to fully turn the chuck set to the right and left.



5. Problem with Chisel / Web Thinning - Check List

- ① For grinding the web thickness of a drill, when inserting or taking out the chuck set from web thinning shelf, make sure the pin is in the middle of the slot. (See page 13, Fig 8-2)
- ② While changing grinding wheel, the flange and the center hole of grinding wheel should be kept clean.
- ③ Make sure the flank of a drill is sharpened completely, uncompleted grinding will cause problem for chisel.
- ④ While grinding, turn the chuck set clockwise and counterclockwise to the end on the grinding shelf.
- ⑤ Check the clearance of chuck set.
- ⑥ Check the clearance of web thinning shelf.
- ⑦ While grinding, do not use too over forcing power to push.
- ⑧ Check the condition of the drill, if the drill is deformed, it can't be used.
- ⑨ Check the drill, Helix of a drill has burr or damaged, the part should be cut off.

6. In case of product or component damage, switch off the machine and disconnect the power cord. Contact your local authorized supplier for repair or replacement.

